

Self-Tapping Screws Head Dimensions

Flat Undercut

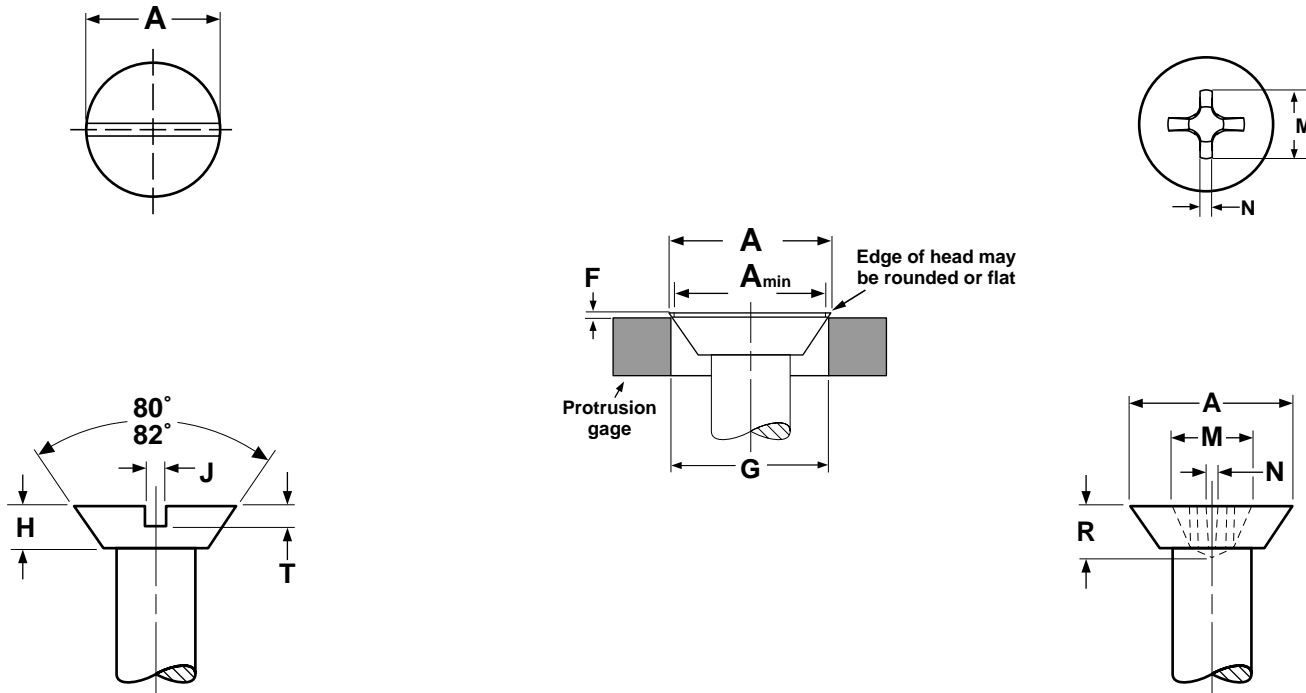

UNDERCUT FLAT HEADS FOR SELF-TAPPING SCREWS																	ASME B18.6.4-1998	
Nominal Size	These Lengths or Shorter are Undercut		A		H		J		T		M	R	N	F		G	Phillips Driver Size	
			Head Dimensions				Slot Dimensions				Recess Dimensions			Protrusion Above Gaging Diameter		Gaging Diameter		
			Diameter		Height		Width		Depth		Diam.	Depth	Width	Max	Min			
	Types A & AB	Other Types	Max	Min	Max	Min	Max	Min	Max	Min	Ref	Ref	Ref	Max	Min			
0	3/16	1/8	.112	.096	.025	.018	.023	.016	.011	.007	.062	.035	.014	-	-	-	0	
1	3/16	5/32	.137	.120	.031	.023	.026	.019	.014	.009	.070	.043	.015	-	-	-	0	
2	3/16	3/16	.162	.144	.036	.028	.031	.023	.016	.011	.088	.048	.017	.029	.017	.124	1	
4	1/4	1/4	.212	.191	.047	.038	.039	.031	.022	.014	.110	.070	.018	.032	.019	.172	1	
6	5/16	5/16	.262	.238	.059	.048	.048	.039	.027	.017	.140	.066	.025	.036	.021	.220	2	
7	3/8	3/8	.287	.262	.064	.053	.048	.039	.030	.019	.148	.074	.027	.037	.022	.243	2	
8	7/16	7/16	.312	.285	.070	.058	.054	.045	.032	.021	.168	.094	.029	.039	.023	.267	2	
10	1/2	1/2	.362	.333	.081	.068	.060	.050	.037	.024	.182	.110	.030	.042	.025	.313	2	
12	9/16	9/16	.412	.380	.092	.078	.067	.056	.043	.028	.226	.110	.030	.045	.027	.362	3	
1/4	5/8	5/8	.477	.442	.107	.092	.075	.064	.050	.032	.244	.124	.032	.050	.029	.424	3	
5/16	13/16	5/8	.597	.556	.134	.116	.084	.072	.062	.041	.310	.157	.053	.057	.034	.539	4	
3/8	-	5/8	.717	.670	.161	.140	.094	.081	.075	.049	.358	.205	.061	.065	.039	.653	4	