

Top View

Note: For depth see table below

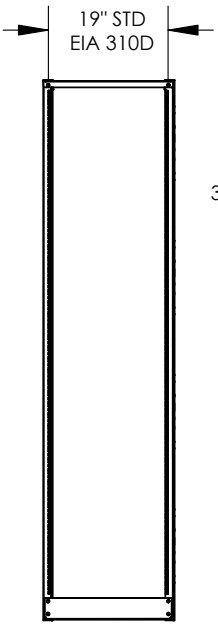

Front View

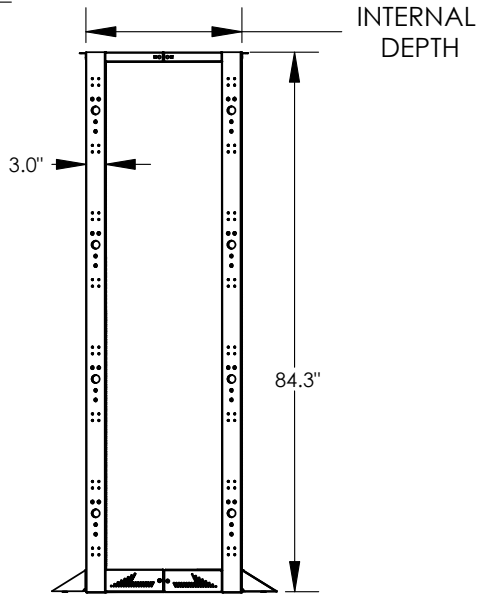

Side View

MOUNTING HARDWARE

ITEM NO.	DESCRIPTION	QTY.
1	12-24 X 5/8" Conical head Screw	56 Pcs
2	PVC black flat washer	56 Pcs
3	Conical screw washer	56 Pcs
4	PVC white flat washer	56 Pcs
5	12-24 X 5/8" Cylindrical head screw	56 Pcs
6	Cable manager hooks	32 pcs w/mounting fasteners

ASSEMBLY HARDWARE

ITEM NO.	DESCRIPTION	QTY.
1	3/8" - 16 UNF hex nut	32 Pcs
2	3/8" Spring washer	32 Pcs
3	3/8"-16x1" UNF screw	32 Pcs

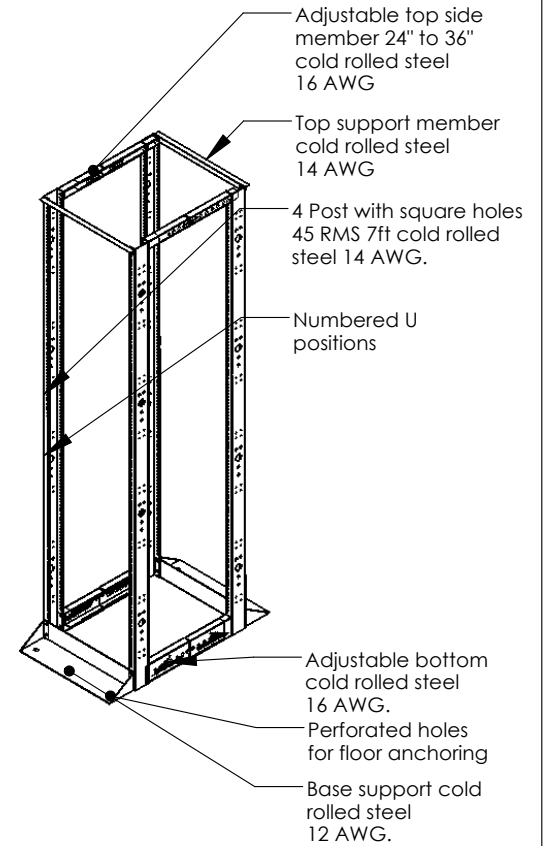

REQUIRED TOOLS

9/16" WRENCH 9/16" SOCKET RATCHET

Mounting Hardware Included

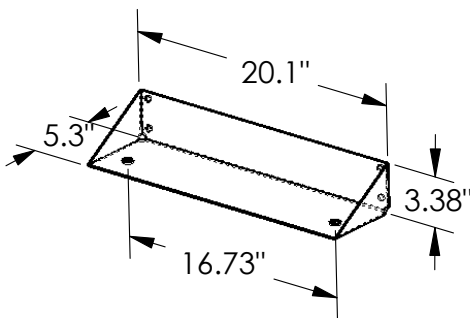

ADJUSTABLE DEPTH		UNLESS OTHERWISE SPECIFIED: DIMENSIONS ARE IN INCHES TOLERANCES: FRACTIONAL ± ANGULAR: MACH ± BEND ± TWO PLACE DECIMAL ± THREE PLACE DECIMAL ±	NAME	DATE
INTERNAL DEPTH	OVERALL DEPTH			
24"	34.6"	INTERPRET GEOMETRIC TOLERANCING PER: MATERIAL	DRAWN	
26.5	39.1"		CHECKED	
29.125"	39.725"		ENG APPR.	
31.5"	42.1	FINISH	MFG APPR.	
34"	44.6"		Q.A.	
36"	46.6"			



SR4 POST		
TITLE:		
4 POST ADJUSTABLE OPEN RACK		
SIZE A	DWG. NO.	REV
SCALE: SIN	WEIGHT:	SHEET 1 OF 1

MODEL: SR4POST ADJUSTABLE OPEN RACK

Assembly Instructions

Contents

- 1 -Base (2 Pcs.)
- 2 -Post (4 Pcs.)
- 3 -Side lower members (4 Pcs.)
- 4 -Center lower members (2 Pcs.)
- 5 -Side upper members (4 Pcs.)
- 6 -Center upper members (2 Pcs.)
- 7- Top support bracket (2 Pcs.)

Assembly hardware

- 3/8"-16 UNF hex nut (32 Pcs.)
- 3/8" X 7/8" Spring washer (32 Pcs.)
- 3/8"-16x1" UNF screw (32 Pcs.)

Required Tools

-  9/16" Wrench
-  9/16" Socket, Ratchet

- * Equipment Hardware
- 12-24 X 5/8" Cylindrical head screw (56 Pcs.)
- PVC black flat washer (56 Pcs.)
- 12-24X5/8" Conical screw washer (56 Pcs.)
- PVC White flat washer (56 Pcs.)
- 12-24 x 5/8 Screw (56 Pcs.)
- Cable manager hooks... (32 Pcs w/mounting fasteners)

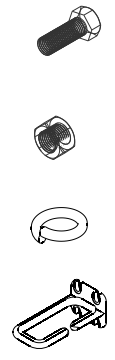
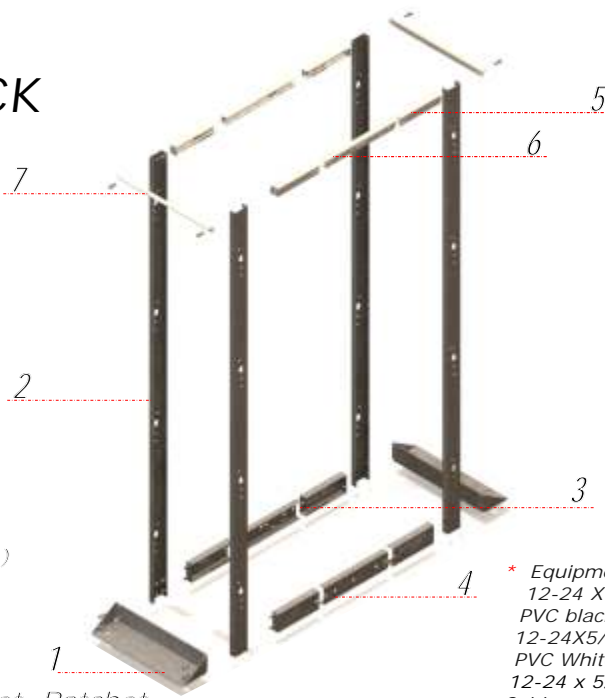

- 1 Assemble Base & Posts**
* Place base on a hard flat surface. Use 3/8" Screws to attach base to each post

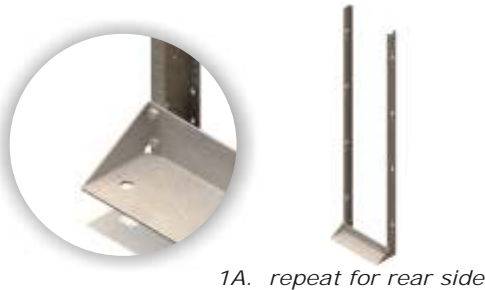

- 2 Assemble top support bracket**
* Verify alignment

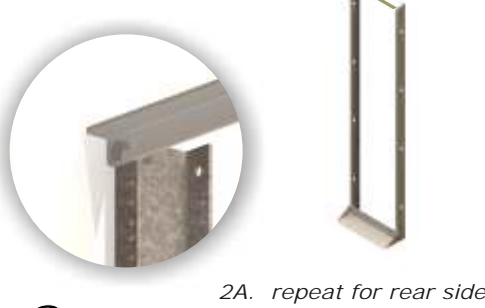

- 3 Pre-Assemble upper and lower side members**
* Set desired depth
Use 3/8" Screws and tighten members



- 4 Install Pre-Assembled upper side members as shown**
*Use included nuts .Fasten tightly



- 5 Install Pre-Assembled lower side members as shown**
* Verify alignment before tightening



- 6 Install Cable Manager Hooks as desired**
* Use included plastic fasteners

