



Telephone Line Distribution Module

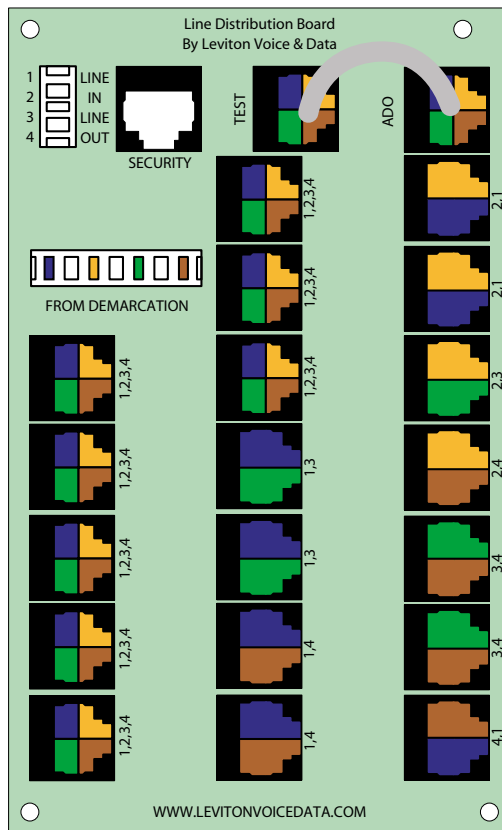

Table of Contents...

Introduction3

TLDM Enhancements, Overview & Comparison3

TLDM Components4

Using the TLDM with the Category 5e Voice & Data Board5

Using the TLDM with the Telephone Patching Expansion Board5

Cascading Multiple TLDMs6

Connecting a Security System to the TLDM6

Pre-Configured Structured Cabling Panel Configurations7

Affected Part Numbers and Summary8



Introduction

The purpose of this white paper is to describe feature changes to the Leviton Voice and Data Telephone Line Distribution Module (TLDM). The TLDM is a telephone distribution device included in many of Leviton's Pre-Configured Structured Cabling Panels (PSCPs), which in turn are part of the Leviton Structured Media™ System. In addition to the TLDM, the PSCPs may contain one or more Category 5e Voice & Data Boards, a 1x6 Video Splitter, or slots for future expansion boards. PSCPs that do not contain a TLDM may contain a 1x9 Bridged Telephone Board. PSCPs may be enhanced with additional Category 5e Voice & Data Modules or 1x6 Telephone Patching Modules (NEW).

TLDM Enhancements - Overview and Comparison

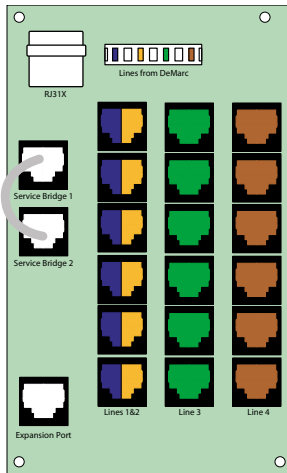

Previous Design

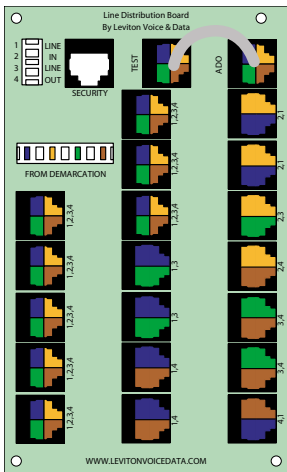

Current Design

The TLDM provides enhanced telephone distribution for phone, fax or modem, via a standard 110-type input connector that wires four telephone lines in from the demarcation point.

Previous Design

The previous design had a limited number of two-line ports, and no four-line ports. A large number of ports were allocated to the third or fourth line, which in most networks are in lower demand. The previous design featured:

- Eighteen jacks.
- Two-line phone service to six jacks. (Lines 1 & 2 only.)
- One-line phone service to twelve jacks. (Line 3 or 4.)
- RJ31X Security System Interface/over-ride jack.

Current Design

The current design provides a larger number of four-line and two-line connections, and considerably greater access to Line 1. This design also isolates the security over-ride functions, which provides greater protection from malfunction. The current design features:

- Nineteen jacks.
- Four-line phone service to eight jacks. (Lines 1, 2, 3 & 4.)
- Two-line phone service to eleven jacks. (In one of these combinations: 1,3; 2,1; 2,4; 4,1; 1,4; 2,3; or 3,4.)
- Optional security system punchdown and auxiliary disconnect jack for security system over-ride.
- Test port and Auxiliary Disconnect Port.

Telephone Line Access Comparison

	Previous Design	Current Design
Line 1 Access	6 Ports as Primary Line	12 Ports as Primary Line 3 Ports as Second Line (2 Line Phone)
Line 2 Access	6 Ports as Second Line (2 Line Phone)	4 Ports as Primary Line 8 Ports as Second Line (2 Line Phone)
Line 3 Access	6 Ports as Primary Line	2 Ports as Primary Line 3 Ports as Second Line (2 Line Phone) 8 Ports as Third Line (3 Line Phone)
Line 4 Access	6 Ports as Primary Line	1 Port as Primary Line 5 Ports as Second Line (2 Line Phone) 8 Ports as Fourth Line (4 Line Phone)

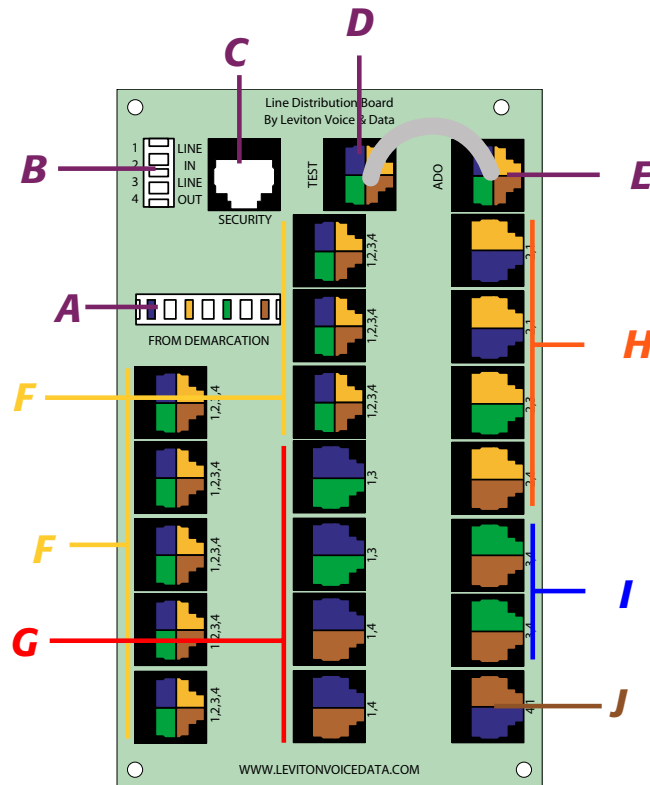

TLDM Components and Features

For detailed instructions on installation and operation, as well as safety precautions, please consult the TLDM instruction sheet that comes with this product.

- A Incoming Telephone Service Punchdown-** To connect up to four incoming telephone lines to the TLDM, punch phone lines from the demarcation point onto this IDC block, marked "FROM DEMARCATION". This will allow them to be bridged, via the TEST and ADO/Expansion jacks, to the RJ-45 ports in combinations as marked next to each port, where they can be accessed via patch cord and routed to other modules. Punch down and trim according to instructions and using industry standard tools.
- B Security System Punchdown (optional) -** To connect an optional security system to the TLDM, divert any one pair (Line 1=blue, Line 2=orange, Line 3=green, Line 4=brown) of incoming phone lines to this IDC punchdown block (see page 6). This enables the security system to over-ride the rest of the module, and commandeer this phone line in case of emergency. Any phone line can be used for this purpose by simply selecting the appropriate pair.
- C Security System Interface (optional) -** Use this RJ-45 Port to connect your security system equipment.
- D TEST Port -** Use this port to bridge the incoming phone lines to the rest of the board by connecting it to the ADO/Expansion Port with the flat telephone patch cord, included. The TEST port also enables testing of the incoming phone lines from the demarcation point.
- E ADO/Expansion Port -** Use this port to bridge the incoming phone lines to the rest of the board by connecting them from the TEST Port with the flat telephone patch cord, included. The ADO/Expansion port enables testing of in-home wiring, once it has been patched in from other modules. The ADO can be used as Expansion Port to "cascade" or connect multiple TLDMs (see page 6).
- F Four-line phone service to eight ports.** (Lines 1, 2, 3 & 4)
- G Two-line phone service to four ports with Line 1 as Primary Phone Line.** (Lines 1,4 or 1,3)
- H Two-line phone service to four ports with Line 2 as Primary Phone Line.** (Lines 2,1; 2,4 or 2,3)
- I Two-line phone service to two ports with Line 3 as Primary Phone Line.** (Lines 3,4 only)
- J Two-line phone service to one port with Line 4 as Primary Phone Line.** (Lines 4,1 only)

Using the TLDM with the Category 5e Voice & Data Board

The TLDM is used in conjunction with one or more Category 5e Voice & Data Boards. Simply run cables from remote locations throughout the home and punchdown on the Category 5e Voice & Data Board. Then, using patch cords, connect any port on the TLDM to the appropriate connection on the Category 5e Voice & Data Module, thereby connecting the specified telephone lines to the room of your choice. See the sample configuration, below.

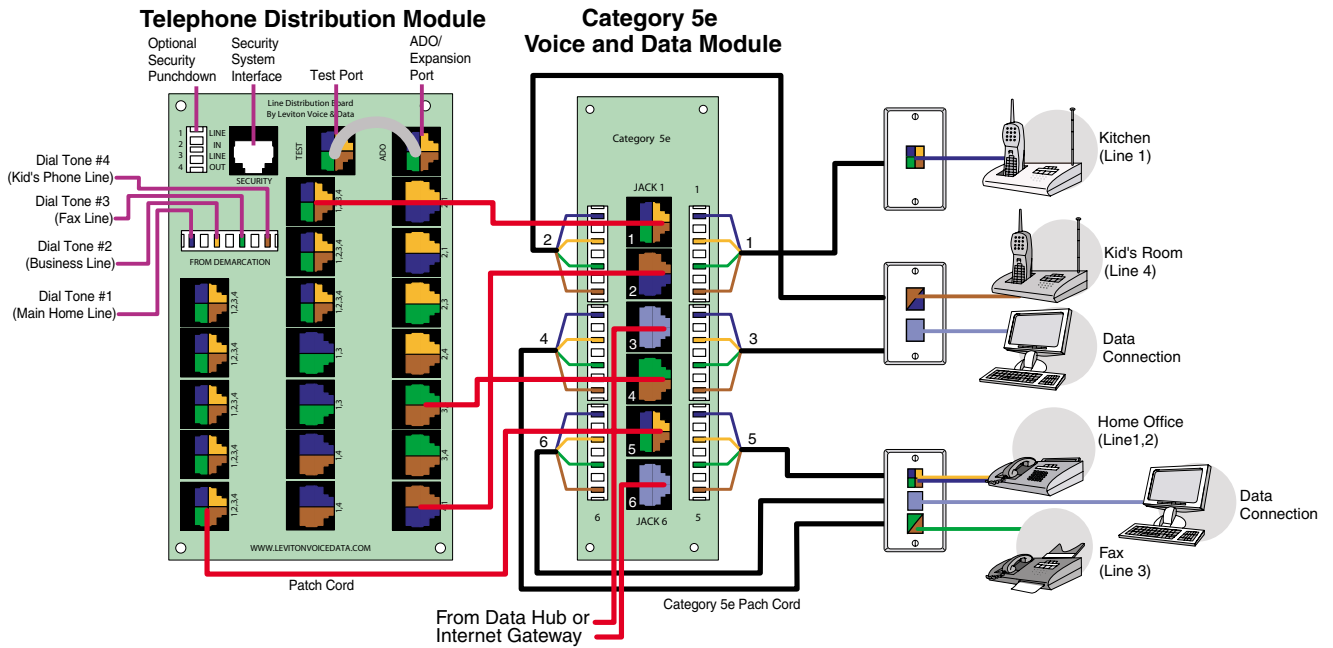

Using the TLDM with the Telephone Patching Expansion Board

The TLDM can be combined with the Telephone Patching Expansion Board, which expands service to six additional ports and can then be patched with Category 5e Voice & Data boards for routing to remote locations throughout the home. See the sample configuration, below. Additional Telephone Patching Expansion Boards can easily be connected via the IDC punchdowns on the primary Telephone Patching Expansion Board.

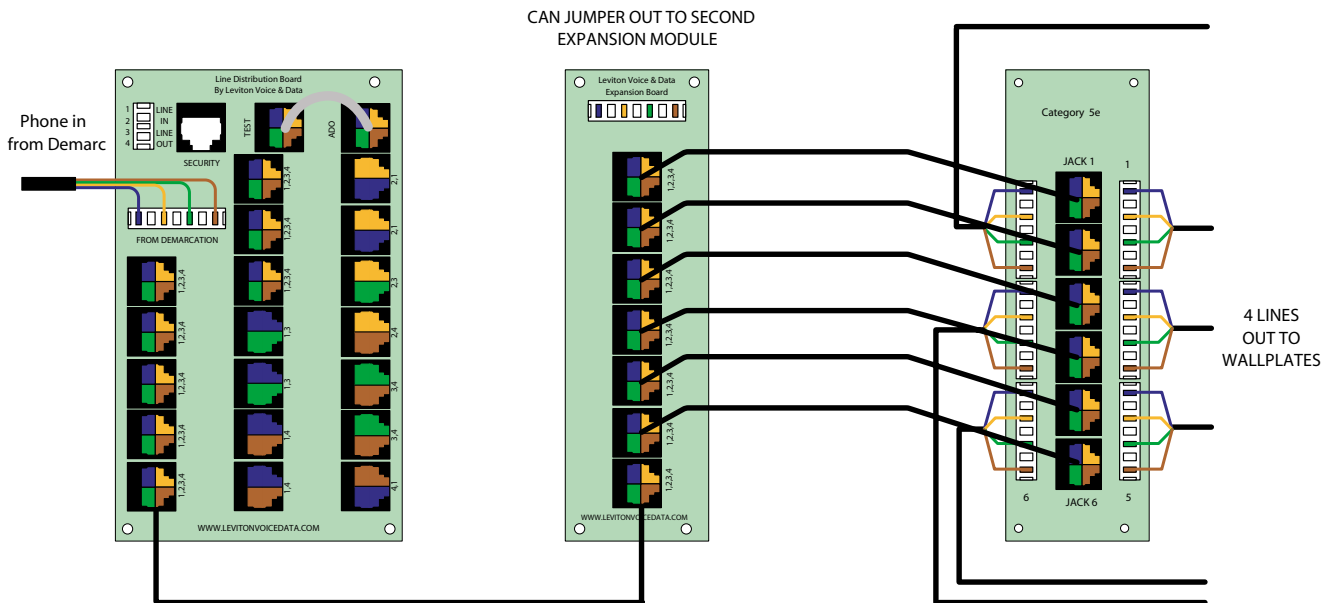

Cascading Two TLDMs

Two or more TLDMs can easily be cascaded to provide 4-line phone service to additional outlets throughout the home. Simply punch incoming service onto the primary panel as usual. Then connect a patch cord from any 4-line port on the primary panel to the ADO/Expansion port on the secondary panel. This will bridge 4-line telephone service from the primary panel to all 18 ports on the secondary panel, bypassing the secondary panel's IDC punchdowns and TEST Port. If two line service is desired, simply connect the patch cord to a two-line port on the Primary TLDM that carries the desired lines.

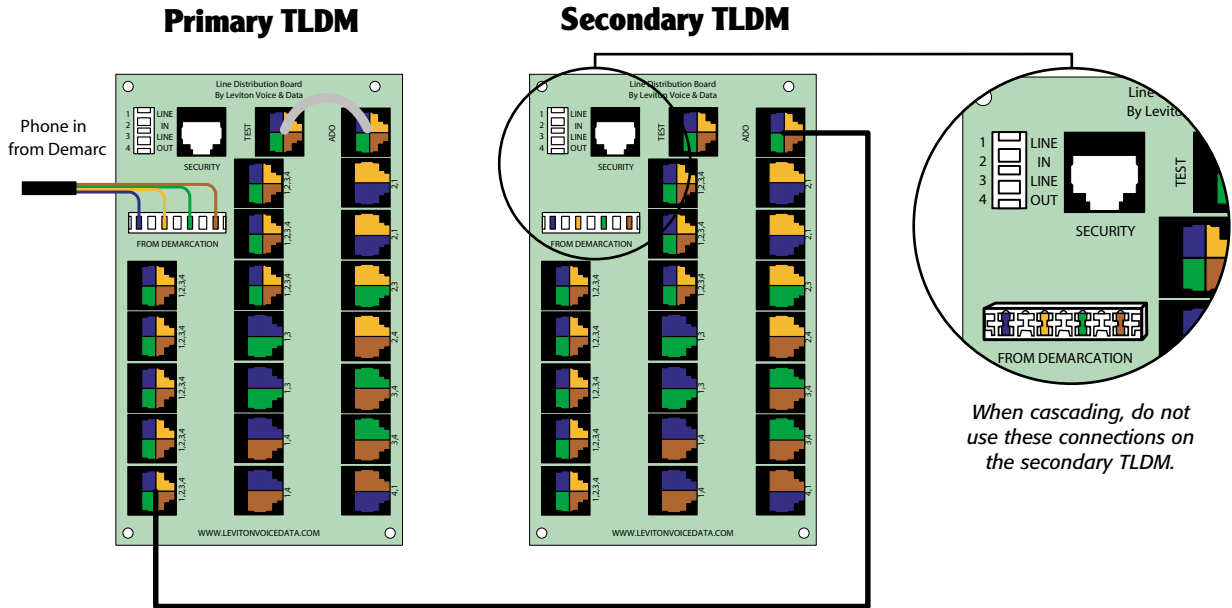

Connecting a Security System to the TLDM

To connect an optional security system to the TLDM, divert any one pair (Line 1=blue, Line 2=orange, Line 3=green, Line 4=brown) of incoming phone lines to the IDC punchdown block on the upper left of the unit. To connect, loop the two wires in through the top two LINE IN slots and then back through the bottom two LINE OUT slots before continuing on to the "FROM DEMARCATION" IDC punchdown, below. Punching down will cut the loop from LINE IN to LINE OUT. This enables the security system to over-ride the rest of the module, and commandeer this phone line in case of emergency.

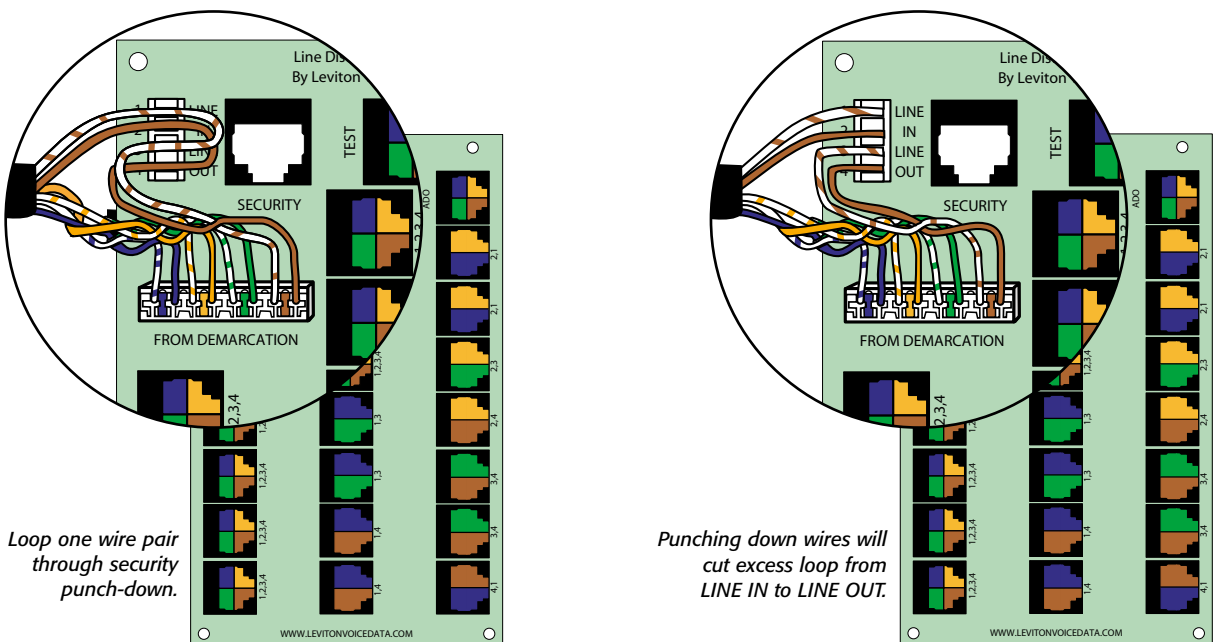

Pre-Configured Structured Cabling Panels

The Telephone Line Distribution Module is available only as part of several Pre-Configured Structured Cabling Panels. These panels combine some of Leviton's most popular voice, data and RF modules to create an economical one-stop home and office media distribution point. The following panels include the new Telephone Line Distribution Module:

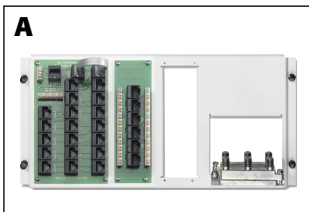

[A] Advanced Home Telephone and Video Panel

Consists of:

- (1) Telephone Line Distribution Module
- (1) Category 5e Voice & Data Board
- (1) 6-way Video Splitter
- Bridge multi-line telephone (in assorted combinations of 2 or 4 lines) to 6 locations. (Cascade with other panels and boards for additional locations.)
- Route video to 6 locations
- Patch data or telephone service to 6 (additional) locations

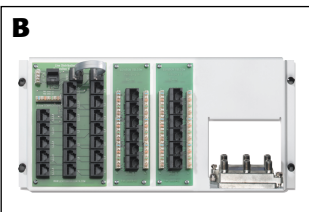

[B] Advanced Small Office Panel

Consists of:

- (1) Telephone Line Distribution Module
- (2) Category 5e Voice & Data Board
- (1) 6-way Video Splitter
- Bridge multi-line telephone (in assorted combinations of 2 or 4 lines) to 12 locations. (Cascade with other panels and boards for additional locations.)
- Route video to 6 locations
- Patch data or telephone service to 12 (additional) locations

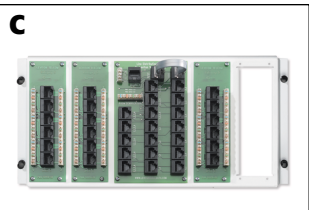

[C] 18-Port Structured Media™ Panel

Consists of:

- (1) Telephone Line Distribution Module
- (3) Category 5e Voice & Data Boards
- Bridge multi-line telephone (in assorted combinations of 2 or 4 lines) to 18 locations. (Cascade with other panels and boards for additional locations.)
- Patch data or telephone service to 12 (additional) locations

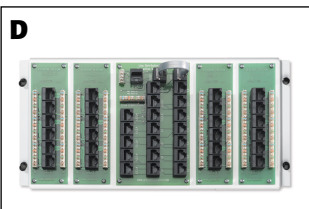

[D] 24-Port Structured Media Panel

Consists of:

- (1) Telephone Line Distribution Module
- (4) Category 5e Voice & Data Boards
- Bridge multi-line telephone (in assorted combinations of 2 or 4 lines) to 19 locations. (Cascade with other panels and boards for additional locations.)
- Patch data or telephone service to 12 (additional) locations

Affected Part Numbers

Introduction of the new Telephone Line Distribution Module affects Pre-Configured Structured Cabling Panel part numbers:

	<u>Old P/N</u>	<u>New P/N</u>
Advanced Home Telephone & Video Panel	030-47603-AHT	031-47603-AHT
Advanced Small Office Panel	040-47603-ASO	041-47603-ASO
18-Port Structured Media™ Panel	050-47603-18P	051-47603-18P
24-Port Structured Media™ Panel	060-47603-24P	061-47603-24P
Telephone Patching Expansion Board (NEW)		100-47609-EMP
8-Conductor Flat Telephone Patch Cord 8" long (NEW)		100-42400-8FG

Summary

Leviton's Telephone Line Distribution Module is used for providing connections for phone, fax or modem, and supports up to 19 telephone outlets throughout the home or office. The module comes equipped with a security interface that is connected to a desired line chosen by the user. Designed for placement in Leviton's Structured Media™ Centers, the Telephone Line Distribution Module is an essential part of Leviton's Pre-Configured Structured Cabling Panels, which create a one-stop central wiring and distribution point for home or office. For more information, call 800-722-2082 or visit www.levitonvoicedata.com.