

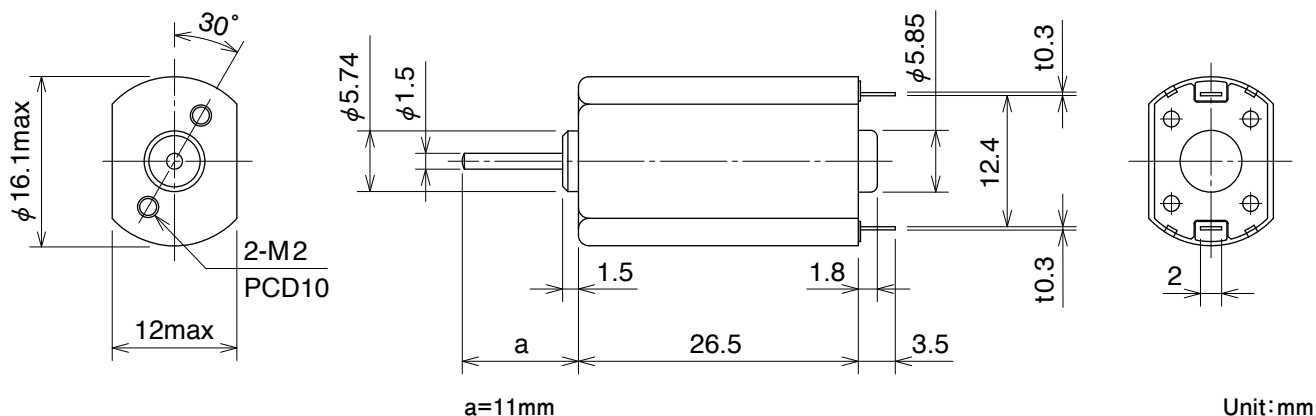

PPN13

■ モータ外觀寸法 External Dimensions

Weight:17g



■ 参考特性 Reference Characteristics

型式 Model	電圧 Voltage		無負荷 No Load		定格負荷 Rated Load		定格負荷 Rated Load		起動トルク Starting Torque		起動電流 Starting Current
	駆動電圧 Operating	定格電圧 Rated	回転数 Speed	電流 Current			回転数 Speed	電流 Current			
	(V)	(V)	(min ⁻¹)	(mA)	(gf·cm)	(mN·m)	(min ⁻¹)	(mA)	(gf·cm)	(mN·m)	
PPN13PB10C	2 to 9	7.4	7000	29	7.5	0.74	5650	108	39.6	3.9	442
PPN13PB11C	2 to 9	7.4	9100	34	7.5	0.74	7450	137	41.7	4.1	601
PPN13PB12C	2 to 9	5.0	7100	34	5.0	0.49	6100	114	36.6	3.6	618

■ トルク特性 Torque Characteristics

