



ULTRA-MATE® BRAND PRODUCTS

HIGH TECHNOLOGY HOOK FASTENERS

ULTRA-MATE® brand High Technology Hook (HTH) products are engineered molded hook fasteners which provide superior closure with a variety of loops. The result of years of research by Velcro Industries, ULTRA-MATE® products provide an unprecedented range of fastening performance characteristics. Please see individual Product Information Guides for performance specifications.

- **4 proprietary hook shapes**
- **A wide range of closure strengths**
- **Cycling capabilities from disposable to long life**
- **Hook density ranges from 130 to 900 hooks per inch**
- **Polymer properties demanded by the application - UV, flame, moisture and acid resistant**
- **Dielectrically and sonically sealable, sewable**
- **Flexibility - ideal for stitching and slitting, as well as straight and die-cutting**
- **Adaptability - products can incorporate custom features, from unidirectional hooks to wide selvages or channels**
- **Consistent hook shape and height**
- **Available in widths up to 12-3/4 inches**

POLYMERS AVAILABLE

- **Nylon**
- **Polyester**
- **Polypropylene**
- **Polyethylene (High and Low Density)**
- **Vinyl**

METHODS OF ATTACHMENT

- **Sewing**
- **Pressure Sensitive Adhesives (see back cover)**
- **Ultra-Sonic Welding**
- **RF Sealing**

FABRICATION & PACKAGING

- **Straight and Die-Cut Pieces**
- **Cut and Mated Pieces**
- **Scored Pieces**
- **Perforated Pieces and Rolls**
- **Custom Manufactured Straps**
- **Complete Product Assemblies**

In addition, Velcro USA Inc. can package ULTRA-MATE® products for direct shipment to your customers.

- **Poly Bags**
- **Boxes**
- **Thermoform Blisters**
- **UPC Coding**

Linear yardage ULTRA-MATE® products are packaged for customer usage in a variety of methods, including small reels and cross wound spools. Die-cut and straight cut pieces are shipped in packages and quantities consistent with customer usage and attachment methods.

ULTRA-MATE® Brand HTH Fasteners From Velcro USA Inc.

HTH 15 HOOK

- DESIGNED TO ENGAGE IN HIGH PROFILE KNITTED AND WOVEN LOOPS
- 750 HOOKS PER SQUARE INCH
- HOOK HEIGHT: 0.035 IN (0.875 MM)
- AVAILABLE IN STANDARD BACK OR ADHESIVE BACK
- LINT RESISTANT
- STANDARD HOOK PRODUCTS: 704 (POLYESTER), 705 (NYLON 12), 706 (NYLON 12), 711 (HIGH DENSITY POLYETHYLENE)

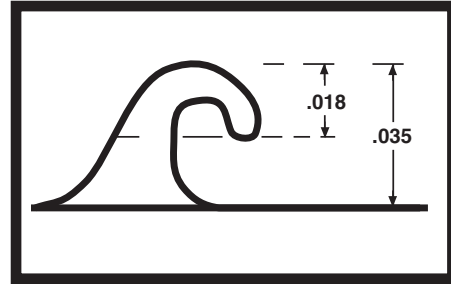

HTH 22 HOOK

- DESIGNED FOR SUPERIOR ENGAGEMENT WITH LOW PROFILE LOOPS
- 900 HOOKS PER SQUARE INCH
- HOOK HEIGHT: 0.028 IN (0.7 MM)
- AVAILABLE IN STANDARD BACK AND ADHESIVE BACK
- LINT RESISTANT
- STANDARD HOOK PRODUCTS: 805 (NYLON 12), 811 (HIGH DENSITY POLYETHYLENE), 848 (VINYL)

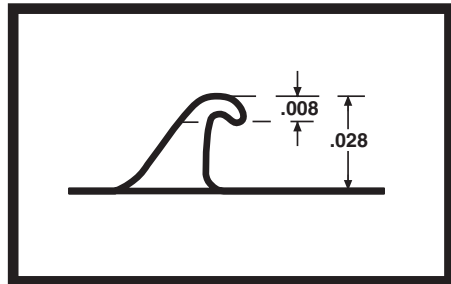

HTH 24 HOOK

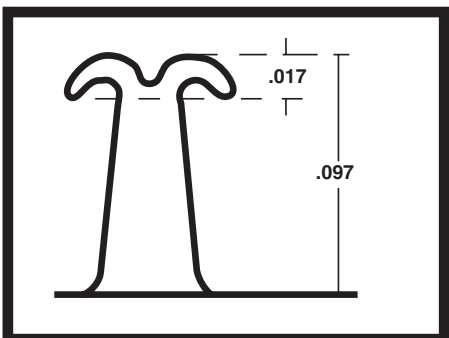

- DESIGNED TO PERFORM LIKE A TRADITIONALLY MOLDED VELCRO® BRAND HOOK
- HIGH STRENGTH, LOW CYCLE CLOSURE
- 130 HOOKS PER SQUARE INCH
- HOOK HEIGHT: 0.0968 IN (2.42 MM)
- IDEAL FOR MOLD-IN APPLICATIONS
- STANDARD HOOK PRODUCTS:
 - 751 - STANDARD BACK OR (NYLON 6/6)
 - 757 - PRESSURE SENSITIVE ADHESIVE (NYLON 12 COPOLYMER)
 - 758 - LAMINATED TO A POLYESTER LOOP FOR EASY ADHESION (NYLON 6/6)

ULTRA-MATE® Brand HTH Fasteners From Velcro USA Inc.

HTH 29 HOOK

- IDEAL FOR LOW-CYCLE OR DISPOSABLE APPLICATIONS
- DESIGNED TO ENGAGE WITH LOW PROFILE LOOPS OR NON-WOVEN FABRICS
- AVAILABLE IN NYLON, POLYPROPYLENE, OR POLYETHYLENE
- 1700 HOOKS PER SQUARE INCH
- HOOK HEIGHT: 0.020 IN (0.5 MM)

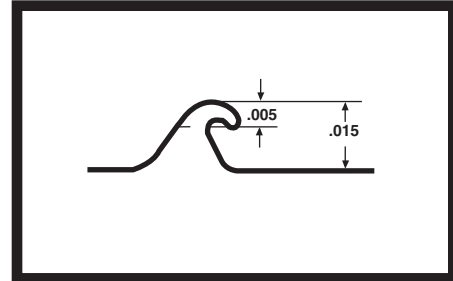

RF WELDABLE HOOK FASTENER

- OFFERS EXCELLENT RF WELDING TO MOST FLEXIBLE VINYL FILMS
- ELIMINATES NEED FOR HEAT-ACTIVATED ADHESIVE OR SOLVENTS
- **HTH 848** - FEATURES A 22 HOOK SHAPE IN VINYL AND IS USED WITH VELCRO® BRAND LOOP 3607 OR LOOP 3906 (LOOPS HAVE VIRGIN VINYL FILM LAMINATED TO FABRIC FOR SEALING TO SUBSTRATE)
- **HTH 748** - FEATURES A 15 HOOK SHAPE IN VINYL AND IS USED FOR ENGAGEMENT WITH HIGH PROFILE LOOPS SUCH AS LOOP 1000

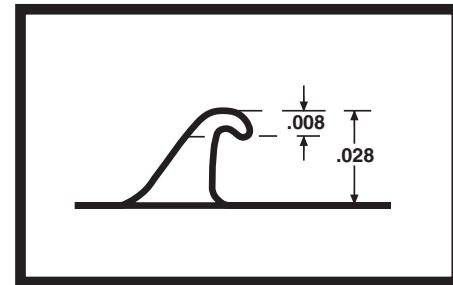

ONE-WRAP® BRAND CORD & CABLE STRAPS

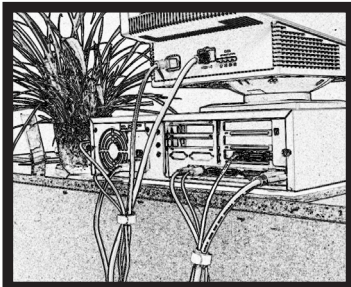

- **ONE-WRAP® STRAPS (HTH 888)** - A UNIQUE BACK-TO-BACK FASTENING SYSTEM FEATURING A POLYETHYLENE HOOK LAMINATED TO A NYLON LOOP WITHOUT THE USE OF AN ADHESIVE; AVAILABLE IN ELEVEN COLORS
- **ONE-WRAP® STRAPS (HTH 889)** - A FIRE RETARDANT VERSION OF ONE-WRAP® TECHNOLOGY MEETS UL 94-V2 AND FAR 25.853 A/B REQUIREMENTS; AVAILABLE IN TWO COLORS
- APPROVED FOR USE IN AIR HANDLING APPLICATIONS PER NEC SECTION (c) & (d)
- MANUFACTURED IN WIDTHS UP TO 12-3/4"
- CAN BE SLIT, PERFORATED AND DIE CUT TO MEET SPECIFIC REQUIREMENTS
- CUSTOM PRINT STRAPS WITH LOGOS, PART OR IDENTIFICATION NUMBERS, OR CONTACT INFORMATION

ADHESIVES	MOST ULTRA-MATE® BRAND PRODUCTS ARE AVAILABLE WITH AT LEAST ONE OF THREE PRESSURE SENSITIVE ADHESIVES.
<p>TEMPO™ (0114)</p> <ul style="list-style-type: none"> A STRONG RUBBER-BASED, PRESSURE SENSITIVE ADHESIVE DESIGNED FOR APPLICATIONS WITH A TEMPERATURE RANGE FROM 0°F TO 160°F. <p>VECTOR™ (0115)</p> <ul style="list-style-type: none"> AN AGGRESSIVE, OLEFIN-BASED PRESSURE SENSITIVE ADHESIVE DESIGNED FOR APPLICATIONS WITH A TEMPERATURE OPERATING RANGE FROM 0°F TO 120°F. 	<p>SPECTRUM™ (0172)</p> <ul style="list-style-type: none"> AN ACRYLIC PRESSURE SENSITIVE ADHESIVE FOR SUPERIOR BOND STRENGTH WITH A TEMPERATURE OPERATING RANGE OF 0°F TO 225°F.

IMPORTANT NOTICE TO PURCHASER

All statements, technical advice and recommendations contained herein are based on tests believed to be reliable, but the accuracy there of is not guaranteed, and the following is made in lieu of all warranties, express or implied: Seller's and manufacturer's only obligation shall be to replace the quantity of product proven to be defective. Neither seller nor manufacturer shall be liable for any injury, loss or damage, direct or consequential, arising out of the use of or the inability to use the product. Before using, user shall determine the suitability of the product for his intended use, and user assumes all risk and liability whatsoever in connection therewith. No statement or recommendation not contained herein shall have any force or effect unless in an agreement signed by officers of seller and manufacturer.

**FOR SALES AND TECHNICAL INFORMATION,
PLEASE CONTACT OUR MANCHESTER, NH SALES HEADQUARTERS AT (800) 225-0180.**

SALES OFFICES AND DISTRIBUTION CENTERS WORLDWIDE

Velcro USA Inc.
406 Brown Avenue
Manchester, NH 03103
Telephone: (603) 669-4892
Facsimile: (603) 669-9271
E-Mail: marketing@velcro.com

Velcro Canada Inc.
114 East Drive
Brampton, ONT, L6T 1C1, Canada
Telephone: (905) 791-1630
Facsimile: (905) 791-5329
E-Mail: canada@velcro.com

<http://www.velcro.com>

Velcro USA Inc. and Velcro Canada Inc. are ISO-9001 and QS9000 registered companies

For transportation sales, please contact Velcro USA Inc., Automotive Division, 1210 Souter, Troy, MI 48083 • (248) 583-6060

